

Introduction

In today's automated world, electric motors are finding their way into new applications, and in ever greater numbers. To succeed they must be cheap, small, powerful and quiet, and offer new levels of control. Integrating the electronics gives manufacturers the edge:

- **cheap** - by cutting the component count for the power supply, analogue processing and electronic interface
- **small** - integration gives access to minimum dimensions; custom device pin-out and standard chip scale packaging fit the tightest spaces

In addition ASICs are the key to cost effective control of **brushless and sensorless** motors with their improved reliability and power. Here, with the added functionality of an ASIC, HMT can provide motor control which is:

- **powerful and quiet** – using dc-dc techniques gives high efficiency and higher power output
- and offers **new levels of control** – the rotor position is measured using the reverse winding voltages without expensive position sensors, which allows **velocity and acceleration control and measurement, braking, and stop detection**



High voltage semiconductor processes

Real motors require real power, and the electronics must deliver the raw amps and volts. This bucks a general trend in electronics for ever lower voltages, and requires specialist knowledge. Future automotive batteries, for example, will be rated at 42V, and direct mains powering is often desirable. HMT have access to suitable semiconductor processes up to 600V, and the design expertise to match.

Power ASICs are exposed to substantial electrical disturbances, such as power surges, operational ESD pulses, and spikes from inductive loads. This is especially true in harsh industrial and automotive environments or where inductive loads can feed currents into an unpowered device.

Operating reliability and circuit protection are a core element of most HMT designs, and we offer protections to automotive and industrial standards.



High temperature ASIC design

ASICs are often assembled into the motor housing, and exposed to the high temperatures generated by the windings, or by the operating environment. With semiconductor processes rated up to 200°C, HMT offers designs for these applications.

Sourcing discrete components for high temperature solutions is often a headache, eliminated with an integration in a purpose built IC. Semiconductor physics is, however, not immune to temperature effects, and HMT's design skill set must be applied to create robust designs which function in specification over the entire temperature range.

As the temperature mounts even higher, even high temperature devices feel the heat, and a thermal management or controlled shutdown is required to protect motor and electronics. Temperature sensing can be cost-effectively integrated into an ASIC.



Life-time reliability testing

ASIC reliability is ensured by design, using parameters and software tools validated by individual foundries. In some applications, however, this is not enough, and an accelerated life-time reliability test is called for to detect early failures and parameter drifts. Here many devices are stressed well above the normal operating temperature to accelerate ageing, and the device parameters are monitored. Careful test design is required to ensure that the devices are correctly stressed, and that the test hardware itself remains stable throughout the test, typically at temperatures above 125°C. HMT offer life-time testing according to JEDEC standards, as well as test conception adapted for customer requirements.



Digital controller design

Digital cores provide the brains expected in emerging motor controllers. HMT offers design and simulation expertise in both verilog and VHDL, and is experienced in the development of both custom minimised processor cores and the use of commercial IP for more complex designs.

In some cases our customers develop the digital core themselves, where this is one of their core competencies. Here we provide supporting guidelines for design for efficient integration and effective test. The back-end processing steps of scan-path insertion, automatic test pattern generation, and place and route can naturally be carried out by HMT.



Modelling and simulation

HMT's **simulation tools and expertise** allow efficient modelling of entire systems, including the motors and sensors. This leads to early concept validation and accurate specification of the ASIC.

Where the models of the external devices are not readily available, HMT have laboratory facilities to extract these parameters from customer products, and to develop these into device models suitable for simulation.

Nothing can beat a demonstration as a tool to boost confidence and understanding. HMT routinely develop **test boards** which accurately mirror the final ASIC function. Beyond showing simple proof of principle, these represent a tool to ensure that the ASIC specification is accurate, and often allow the complete development and test of the digital core at HMT or by the customer before integration commences.

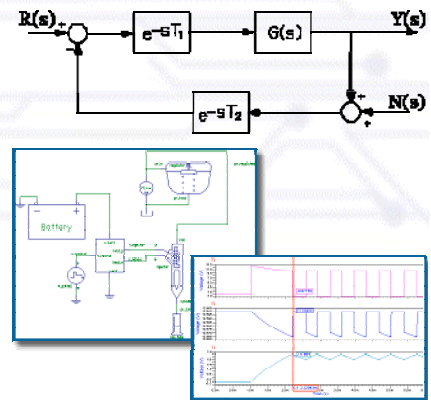

System verification

A complete ASIC typically combines a substantial digital block (>10'000s gates) with analogue blocks (>10'000 transistors). System verification demands **system mixed-signal simulations**, which are processor hungry. Simulations must be carefully designed to extract maximum information within the project schedule.

A thorough test program ensures that every delivered ASIC is within specification. This demands the development of an efficient test program, including purpose test modes in the ASIC. These test modes must themselves be verified to ensure that the first silicon is fully testable.

HMT's skills in system verification set us apart from the competition, and are the key to realising your projects on time and within budget.



HMT Microelectronic AG
Alfred-Aebi-Strasse 75
2503 Biel/Bienne, Switzerland

Tel: +41 (0) 32 365 11 81
Fax: +41 (0) 32 365 82 80
mailbox@hmt.ch

www.hmt.ch

US Representative: Meric Technology, Inc.
Website: <http://www.merictch.com>
Email: sales@merictch.com
Tel: 1 (408) 773-2767
Fax: 1 (408) 773-2781

BELIMO

maxon

micronel

Since 1978, HMT has had a strong activity in ASIC design for motors.